

Lil'MAC Model LMJ4 PA Rescuer



- 600 amp Millipak controller
- No forward/reverse contactors
- Powerful and reliable 6 h.p. tram motor
- Heavy-duty, seven point, rubber-mounted front suspension with coil-over shocks
- 1600# rear Axle and bearings
- Cargo spaces to carry your tools, etc.
- Adjustable stretcher mounts for either backboard or canvas
- Bed designed to carry first aid station container
- Local Damascus distributors you know and trust to give service after the sale

DAMASCUS
Corporation

"We get around UNDERGROUND!!"

Phone: 276-676-2376 or 800-390-7636

Mailing Address:

PO Box 610

Abingdon, VA 24212

<http://www.damascuscorp.com>



Fax: 276-676-0300

Shipping Address:

26864 Watauga Road

Abingdon, VA 24211

e-mail: damascus@naxs.com

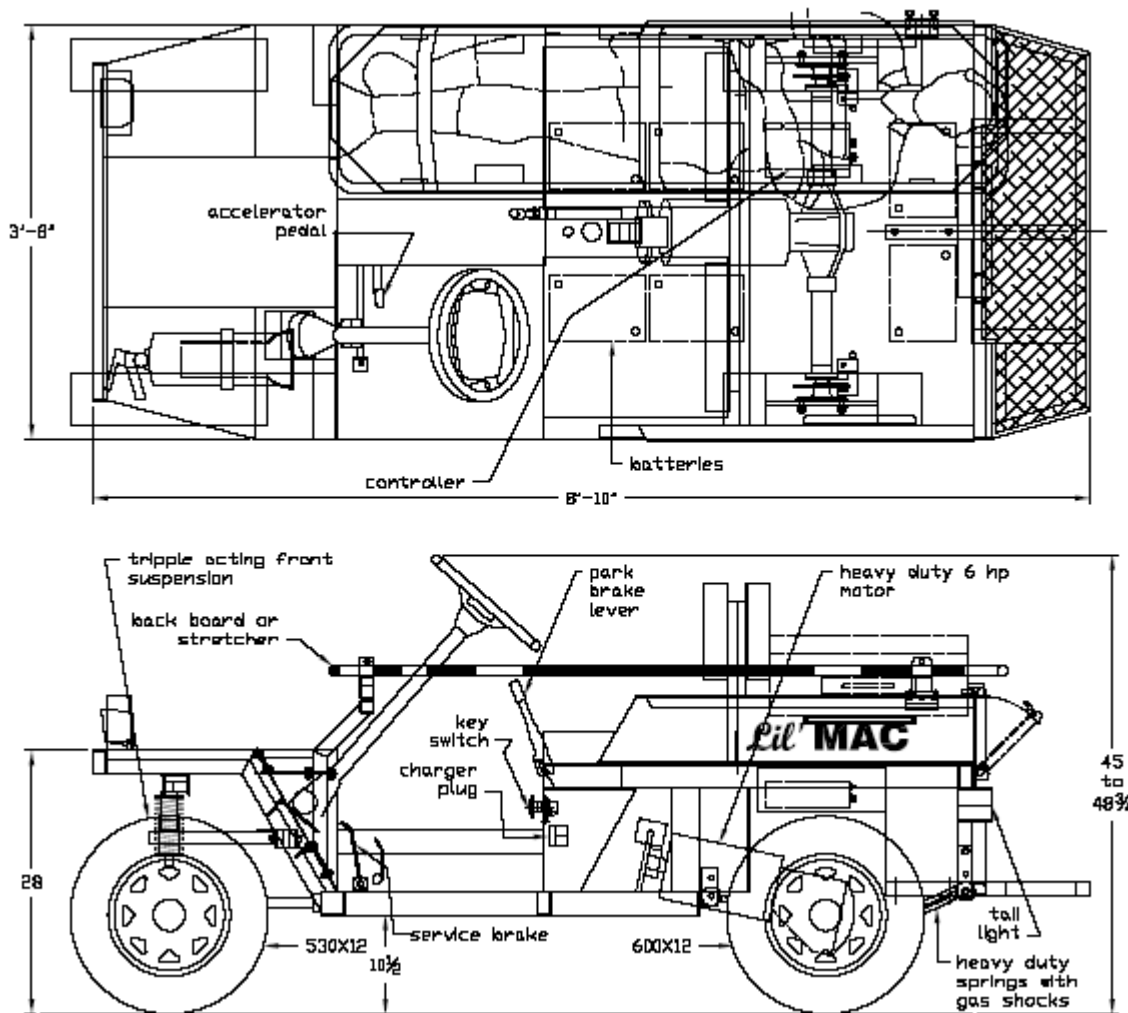

Specifications: Lil'MAC Transporter Model LMJ4-PA Rescuer

Dimensions:	Height: 48 3/4" std. to top of steering wheel. Min. seam height of 65" Width: 3'-8" Length: 10'-7 3/4" Turning radius: 12' I.S.	Motor:	6 horsepower – continuous—TENV– bar wound—heavy duty brush rigging
Ground Clearance:	10 1/2" standard 8 1/2" w/ smaller tires	Brake:	Hydraulic caliper brake @ each rear wheel, Mechanical park brake mounted on motor armature shaft.
Weight:	1165 pounds	Rear Axle:	1600# rear axle with tapered roller bearings. Grease fittings at wheel bearings.
Payload:	2 person plus tools and equipment	Front Suspension:	Triple acting front suspension is rubber mounted for a smooth maintenance free ride.
Electrical:	36 Volt 600 amp controller, no F/R contactors, manual battery disconnect	Rear Suspension:	Heavy duty leaf springs with gas shocks.
Batteries:	6-6 volt 115 minute @ 75 amps	Tires:	Front: 530x12—6 ply rating 10 1/2" g.c. 570 x 8 – 6 ply rating 8 3/4" g.c. Rear: 600x12— tractor tread 10 1/2" g.c. 18x9.50x8 – tractor tread 8 1/2" g.c.
Battery Charger:	Lester Electrical Charger. Constant voltage Input: 115 volt –10 amp Output: 48 volt – 18 amps.	Tram Speed:	10 miles per hour, approx.
Headlights:	One front/rear, 36v	Options:	Seats, canopy, tires, lift kit, strobe Light.